

HUGHES 1000 / 25 PRESSURE TRIPLEX PUMP

FEATURES :



- Rugged unit for Offshore cleaning or pressure tests
- 4 Cylinders Diesel Perkins engine with Chalwyn valve, sparks arrestors and emergency shut off
- Diesel tank capacity 150 liters / fuel consumption : 18 LPH at full load
- 25 mm plungers Hughes pump. Max WP 1000 Bar, flow 40 l/min
- Pump skid fitted with 150 liters break tank and 50 microns filter
- Unit fitted in offshore skid 2 m x 1 m x h 1.4 m GW 1.8 ton.
- Hook height 3.5 m



A robust design, the HPS1000 has a specification producing a heavy duty capability for dealing with the more difficult problems of industry.

The close coupled, gear driven power end has pressure lubrication, filtration and oil cooling. Standard adaptor housings are available enabling the pump to be flange mounted to a diesel engine flywheel housing or electric motor ensuring extremely

compact and perfectly aligned installations.

For maximum hydraulic efficiency, the in-line valve pump head arrangement is designed to minimise the unswept volume.

This improved design is capable of high pressure to high volume with outstanding seal, plunger and valve life.

General Dimensions - typical pump build

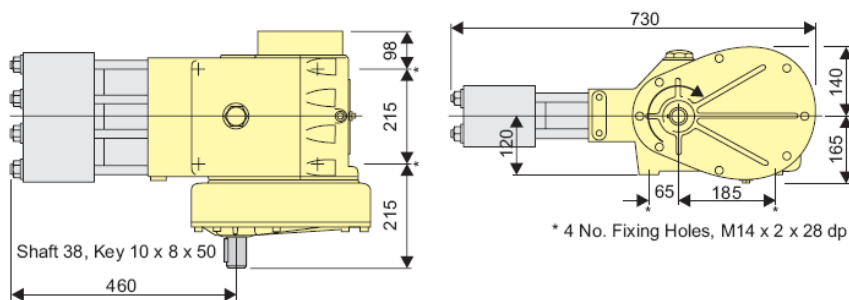

Approx weight - 230 kg (with gearbox)

Port Gentil:

juan.Guerrero@ois-group.com
olivier.vacher@ois-group.com
bert.bouchard@ois-group.com

Pointe Noire:

jean-pierre.lafont@ois-group.com
ignacio-guerrero@ois-group.com

www.ois-group.com